

S600

Specifications

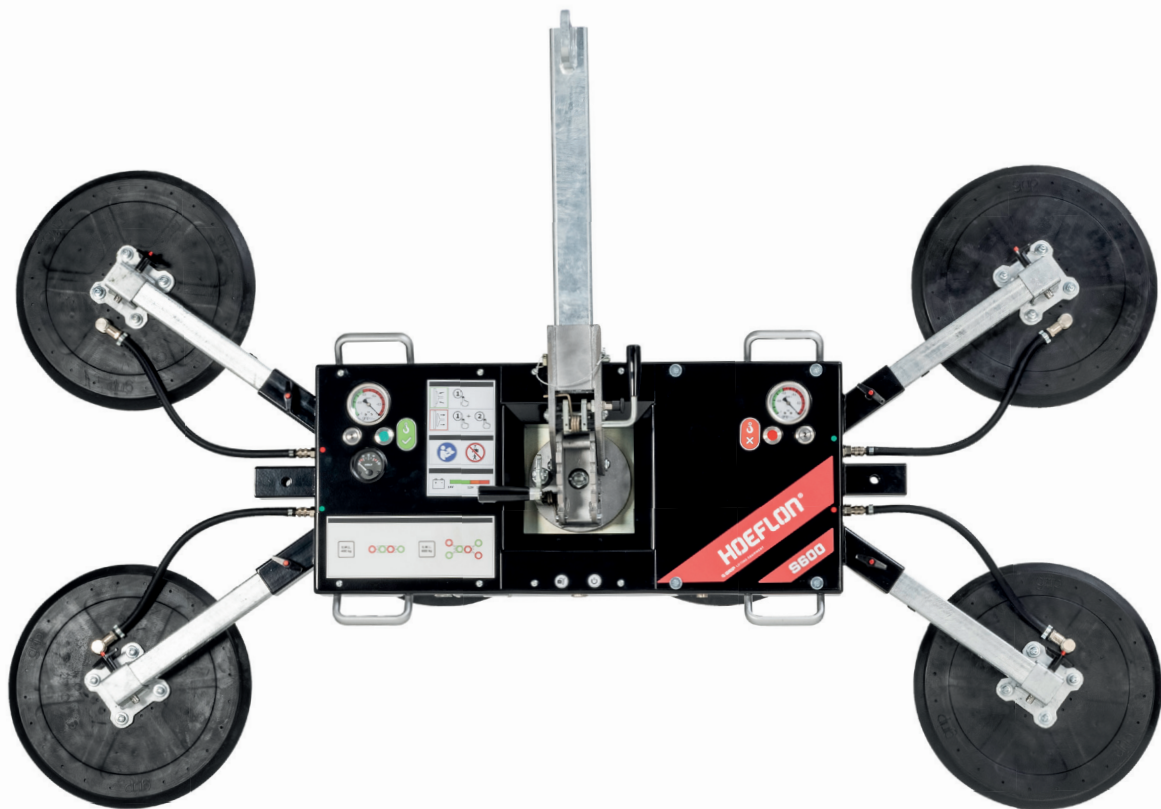

Lifting capacity double circuit:	200 - 600 kg
Machine weight:	50 - 70 kg
Rotation range:	360° with four locking positions
Tilting range:	90° with six locking positions
Machine height:	200 mm
Battery:	12VDC, 10Ah

S600

Specifications

The vacuum lifter for glass up to 600 kg. Equipped with double vacuum system as standard. The various configurations make this machine our all-rounder, suitable for projects small and large.

Unique features

- Compatible with spider and inline suction lifters
- Compact transport on trolley
- Maximum lifting capacity: 600 kg

Delivered standard with:

- Remote control
- Transport trolley
- Long lifting arm
- Short lifting arm
- Swappable battery system incl. spare battery
- Protective covers for suction cups



Specifications

- Manual tilting with 6 locking positions and continuous adjustment
- Manual rotation with 4 locking positions
- Radio remote control of suction and release
- Interchangeable lifting point for lower overall height
- Transport trolley with pneumatic tyres

Accessories



Battery

Battery charger



Remote control



Short lifting arm

S600

Specifications

600 kg - Spider suction lifter

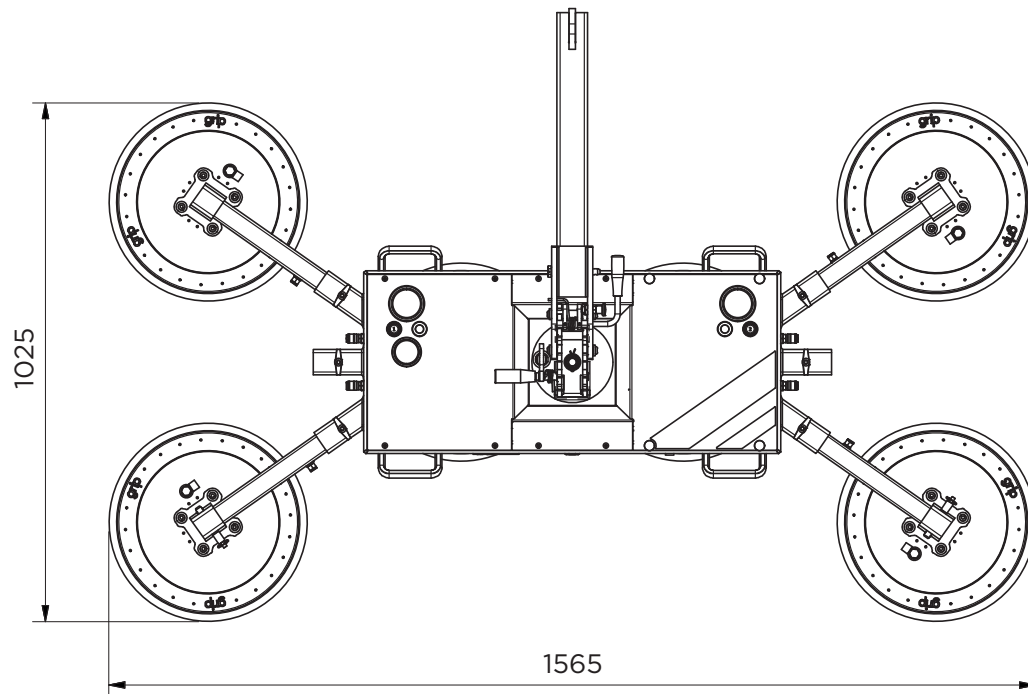

400 kg - Inline suction lifter, long

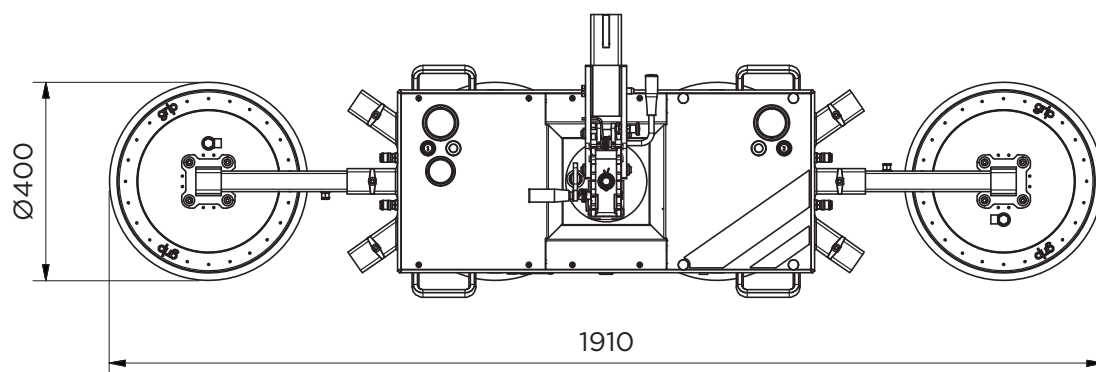

400 kg - Inline suction lifter, compact

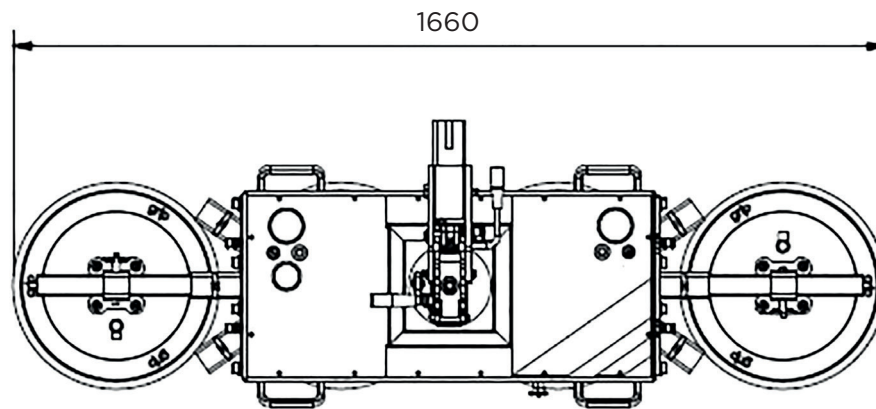

200 kg - Basic unit

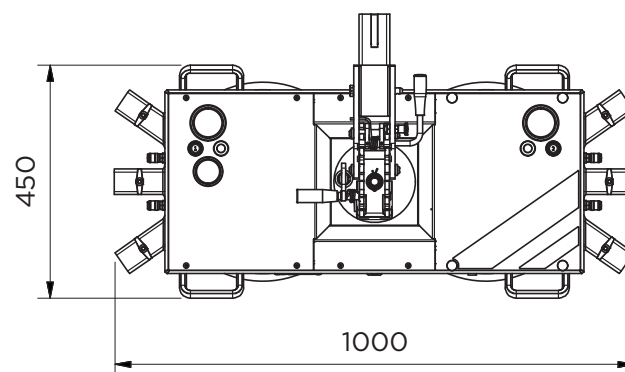

S600

Specifications

HOEFLON®

Your Hoeflon contact person

Hoeflon machines are functional and offer optimal power and reliability. We offer many possibilities and help you come up with solutions.



Hoeflon International B.V.
Zwolleweg 2
3771 NR Barneveld, NL

T +31 (0)342 400288
info@hoeflon.com
KVK 66408962

BIC ABNANL2 A
BTW NL856539806B01
IBAN NL96ABNA0457114533

www.hoeflon.com