

S1000

Specifications

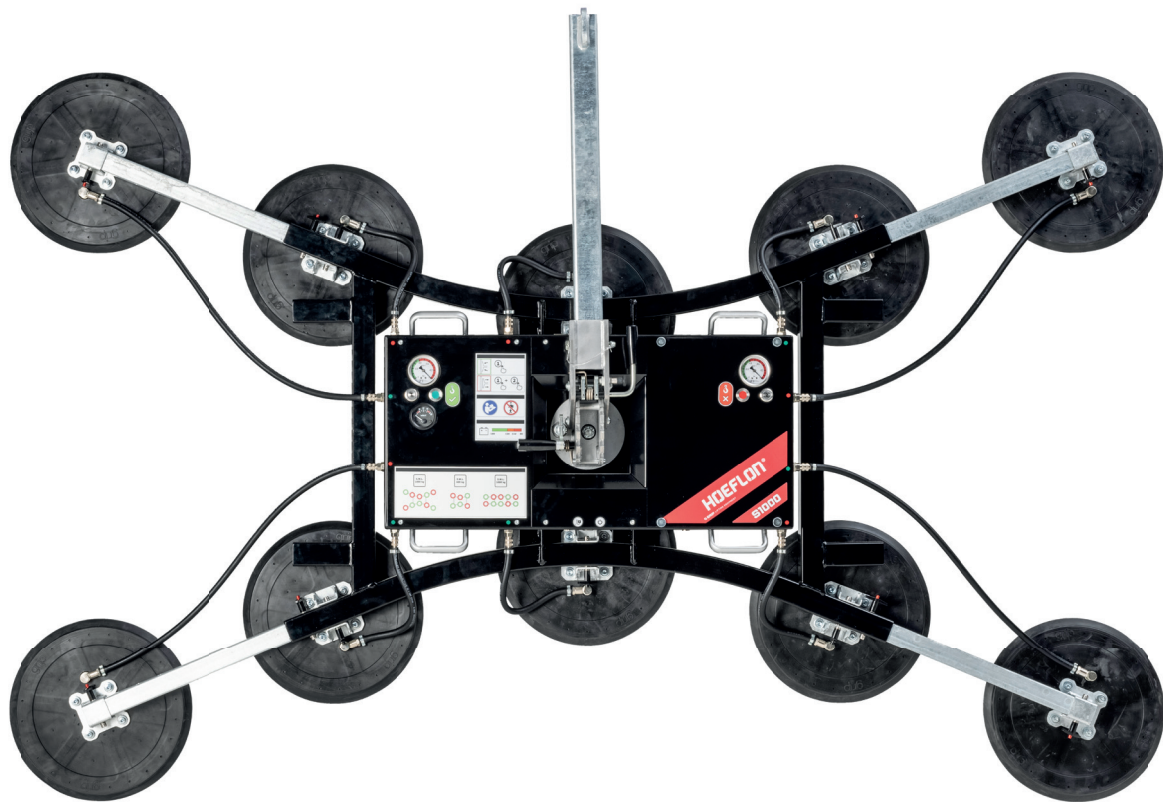

Lifting capacity double circuit:	600 / 1000 kg
Machine weight:	85 / 110 kg
Rotation range:	360° with four locking positions
Tilting range:	90° with six locking positions
Machine height:	190 mm
Battery:	12VDC, 10Ah

S1000

Specifications

The Hoeflon S1000 suction lifter is a premium quality multifunctional glass lifter, with exceptional fit and finish, at a very competitive price.

All our products are designed in close cooperation with users from the field. This results in products that are a class apart when it comes to the details and provide the user with every convenience in daily use.

Unique features

- Compact basic unit for glass with small dimensions
- Spider shape with large spread provides greater ease of installation, speed and safety with large-sized glass
- Lightweight design

Delivered standard with:

- Remote control
- Transport trolley
- Long lifting arm
- Short lifting arm
- Swappable battery system incl. spare battery
- Protective covers for suction cups

Accessories



Battery

Battery charger



Remote control

Short lifting arm

Specifications

- Short lifting arm provides very compact dimensions for when glass installation space is limited
- Long lifting arm allows almost vertical hanging of large-sized glass
- Angle adjustment on the Hoeflon lifting arm provides extra safety and convenience for indoor glazing installation because the angle can be fixed in different positions
- Double vacuum circuit, meeting the requirements of the EN 13155 directive, ensures maximum safety and installation speed because external fall protection is no longer necessary
- Radio remote control provides extra installation speed and convenience
- The overall width of the machine is very low, which means that work can also be carried out between the facade and scaffolding

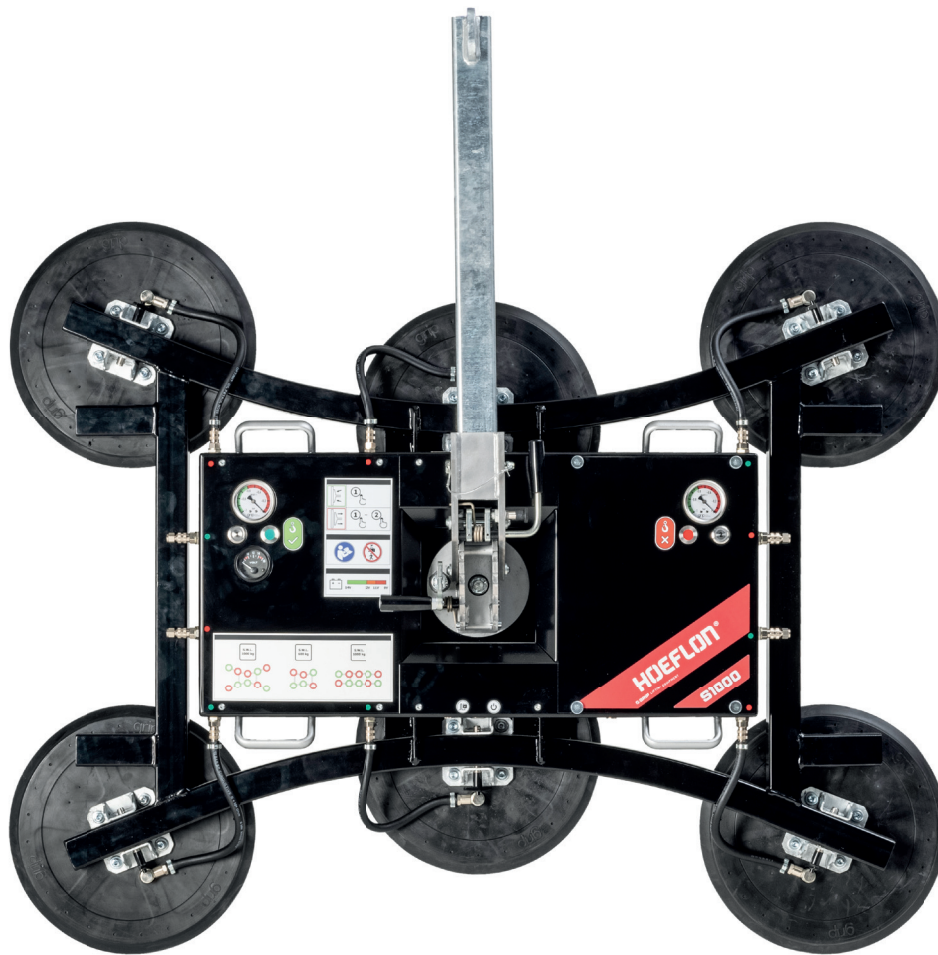

S1000

Specifications

SWL 600 kg - Spider suction lifter

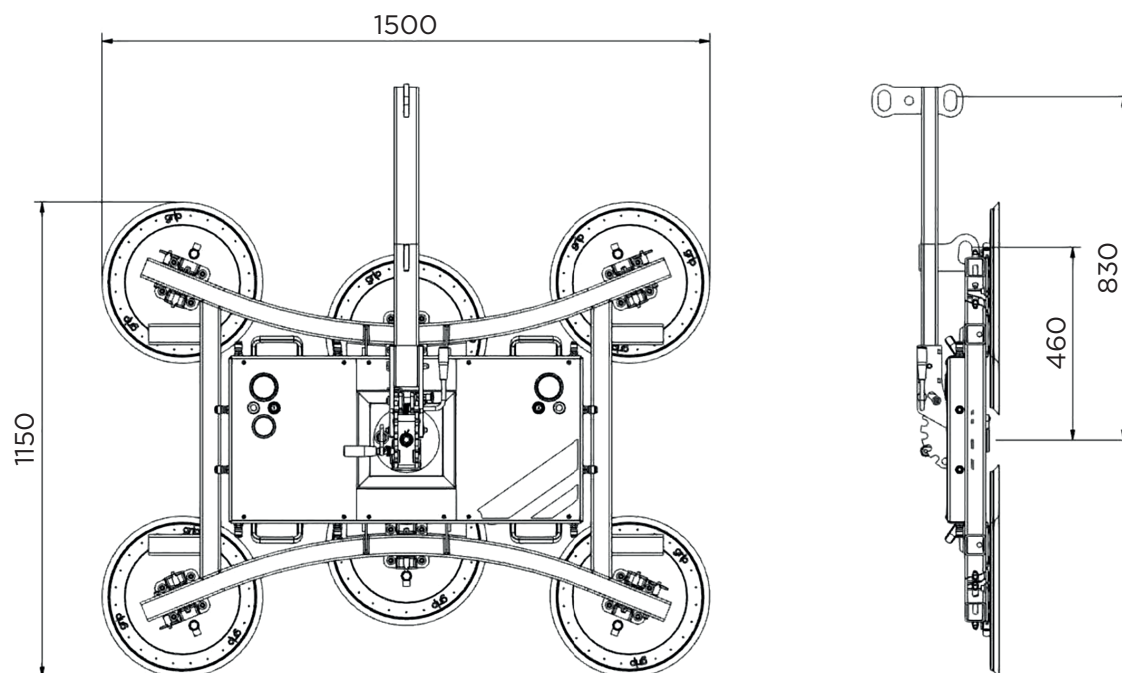

SWL 1000 kg - Inline suction lifter

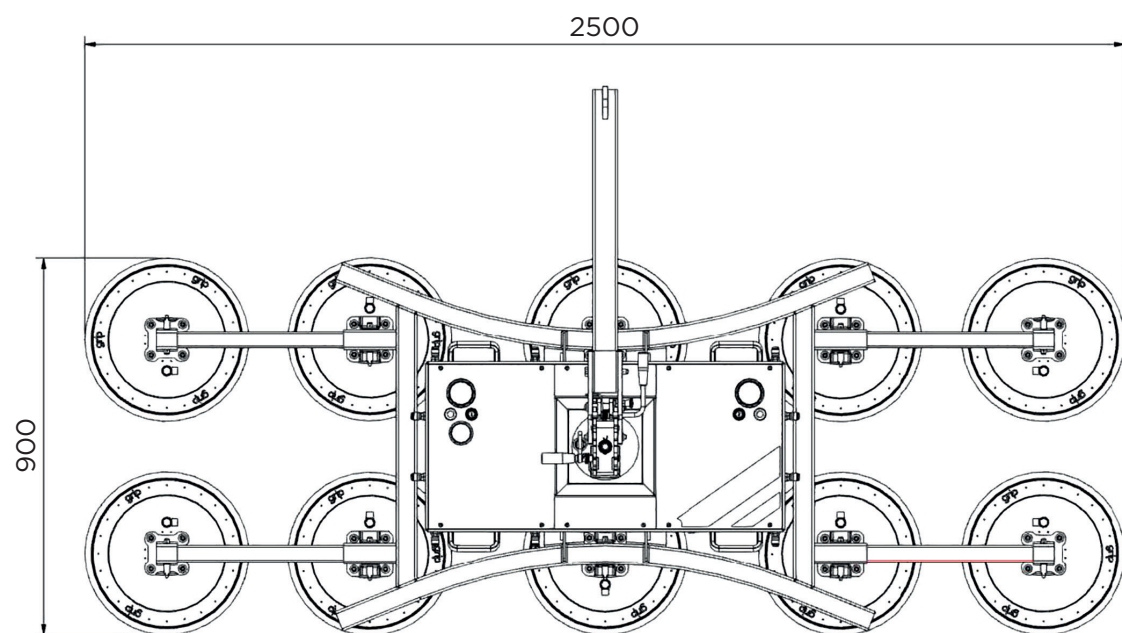

SWL 1000 kg - Spider suction lifter

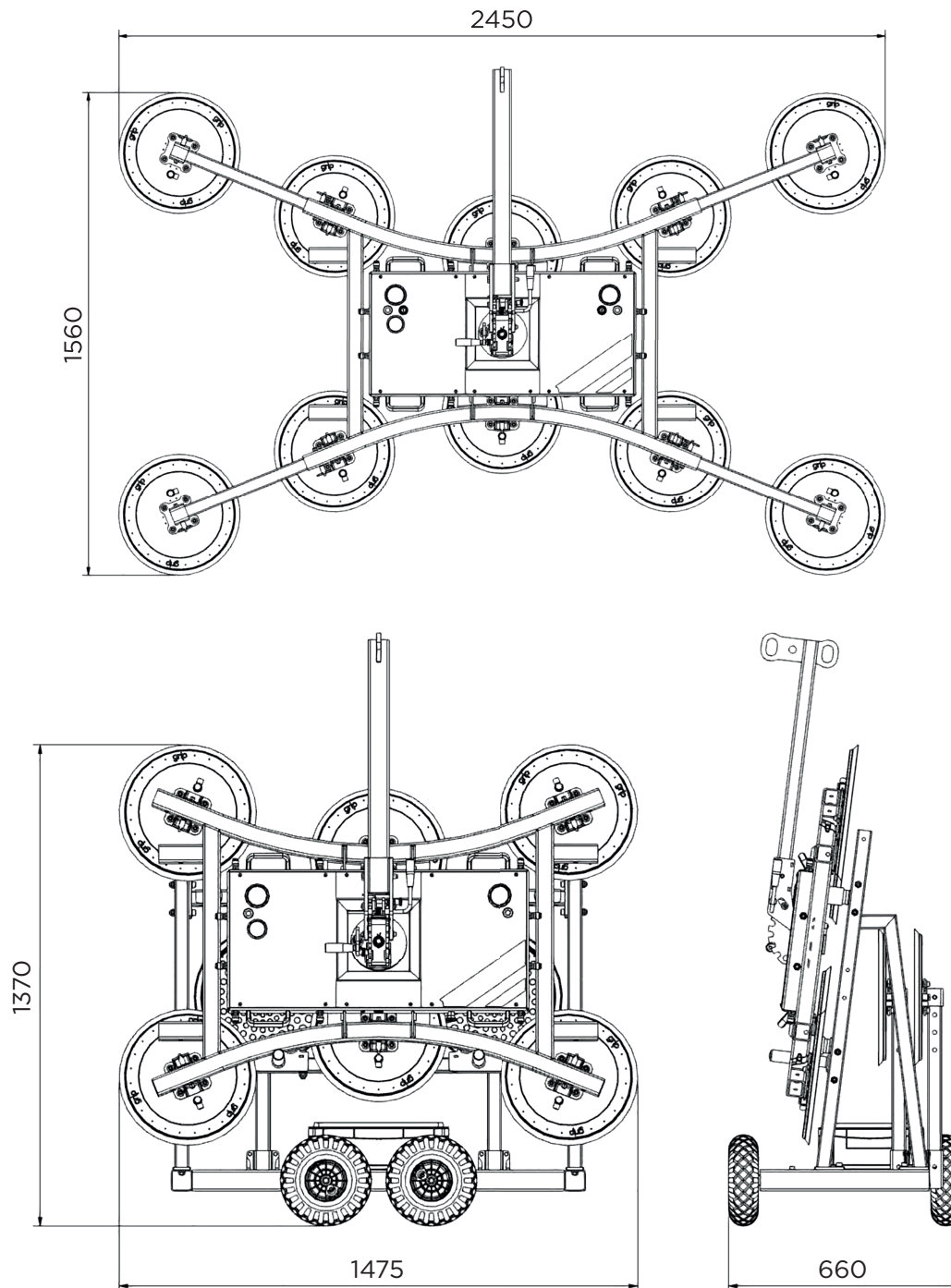

S1000

Specifications

HOEFLON®

Your Hoeflon contact person

Hoeflon machines are functional and offer optimal power and reliability. We offer many possibilities and help you come up with solutions.



Hoeflon International B.V.
Zwolleweg 2
3771 NR Barneveld, NL

T +31 (0)342 400288
info@hoeflon.com
KVK 66408962

BIC ABNANL2 A
BTW NL856539806B01
IBAN NL96ABNA0457114533

www.hoeflon.com